

Schémas de puissance

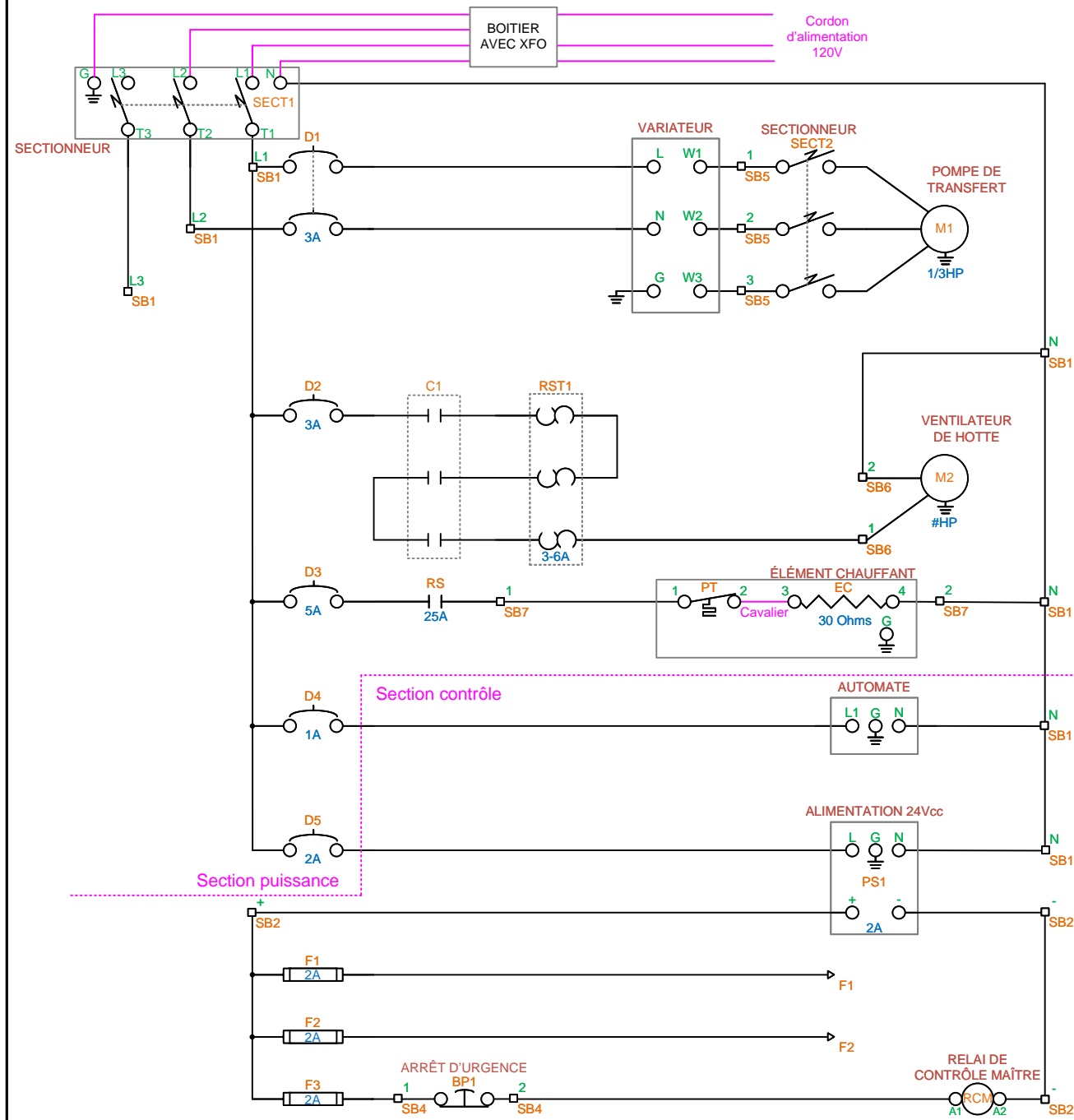

| | | | |
|------|-----------------|--------|--------|
| - | - | - | - |
| - | - | - | - |
| - | - | - | - |
| A | PRÉ-PUBLICATION | 12-Jan | É.B. |
| CODE | DESCRIPTION | DATE | DESSIN |



OLYMPIADES QUÉBÉCOISES DES
MÉTIERES ET TECHNOLOGIES
MÉTIER 19
ÉLECTRONIQUE INDUSTRIELLE

| | |
|----------------|---|
| 1 | 4 |
| CONCOURS: 2025 | |
| DATE: Jan-2025 | |

Schémas de contrôle

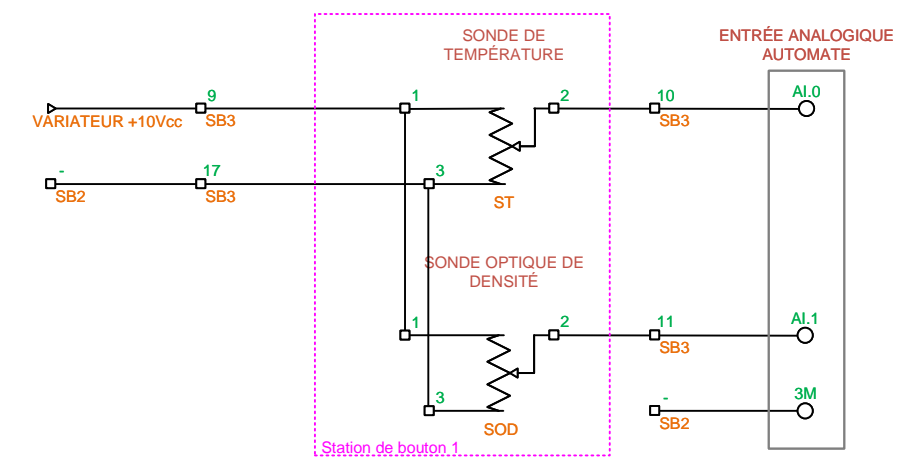
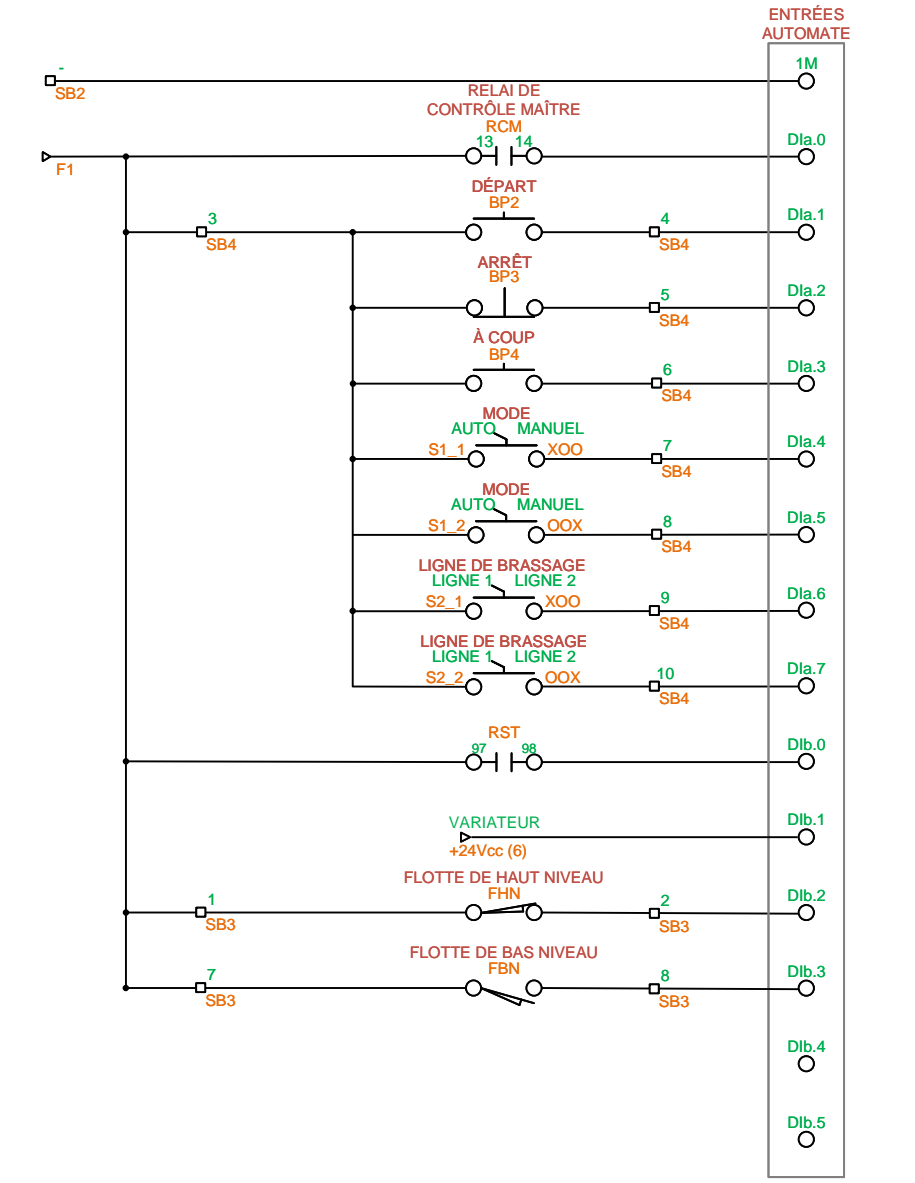
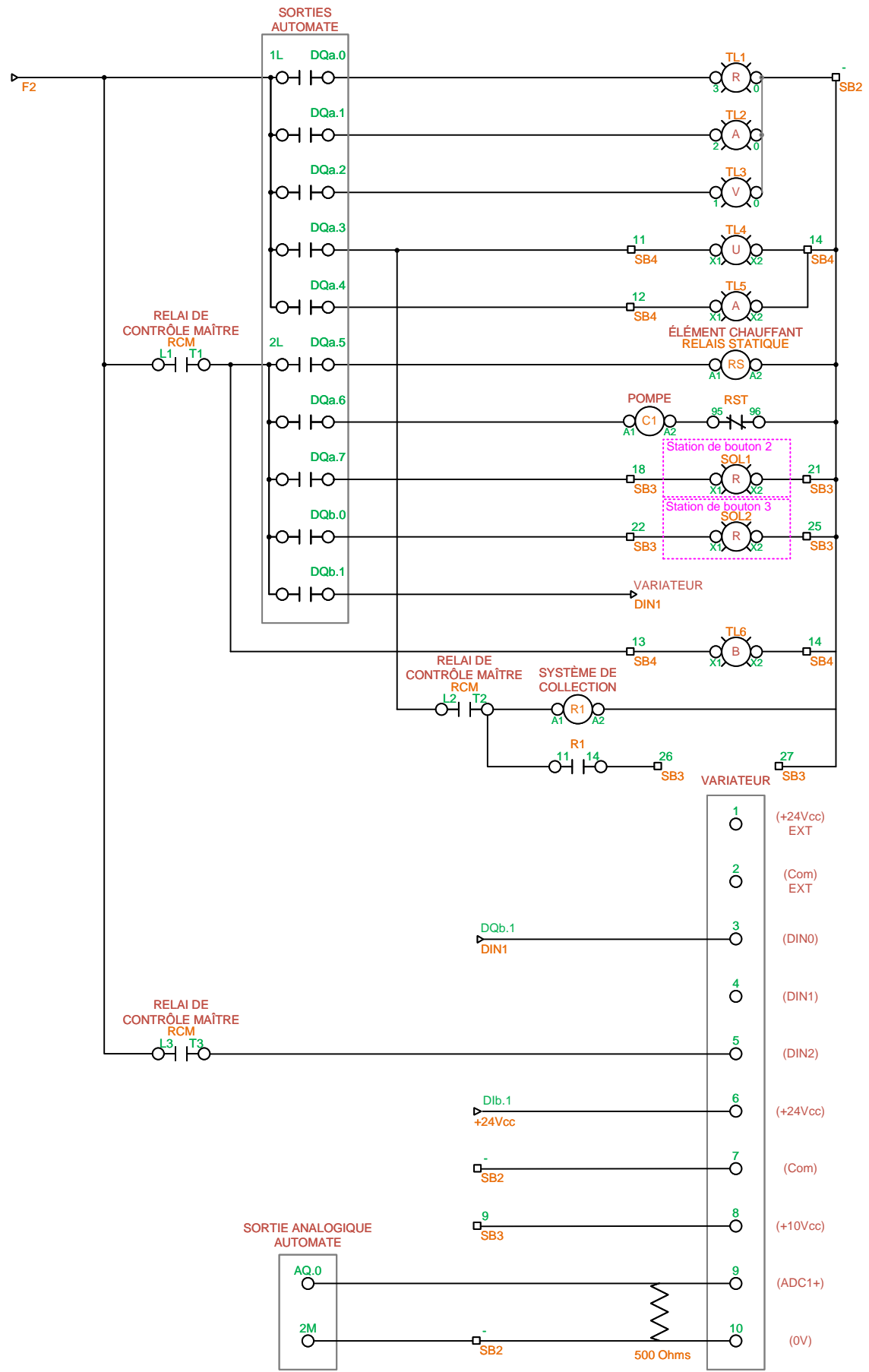

| | | | |
|------|-----------------|--------|--------|
| - | - | - | - |
| - | - | - | - |
| - | - | - | - |
| A | PRÉ-PUBLICATION | 12-Jan | É.B. |
| CODE | DESCRIPTION | DATE | DESSIN |



OLYMPIADES QUÉBÉCOISES DES MÉTIERS ET TECHNOLOGIES
MÉTIER 19
ÉLECTRONIQUE INDUSTRIELLE

2 / 4
 CONCOURS: **2025**
 DATE: Jan-2025

Schémas de l'armoire de commande

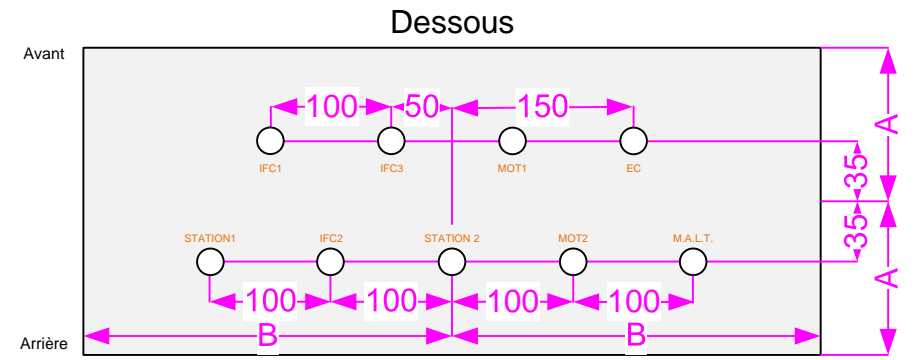
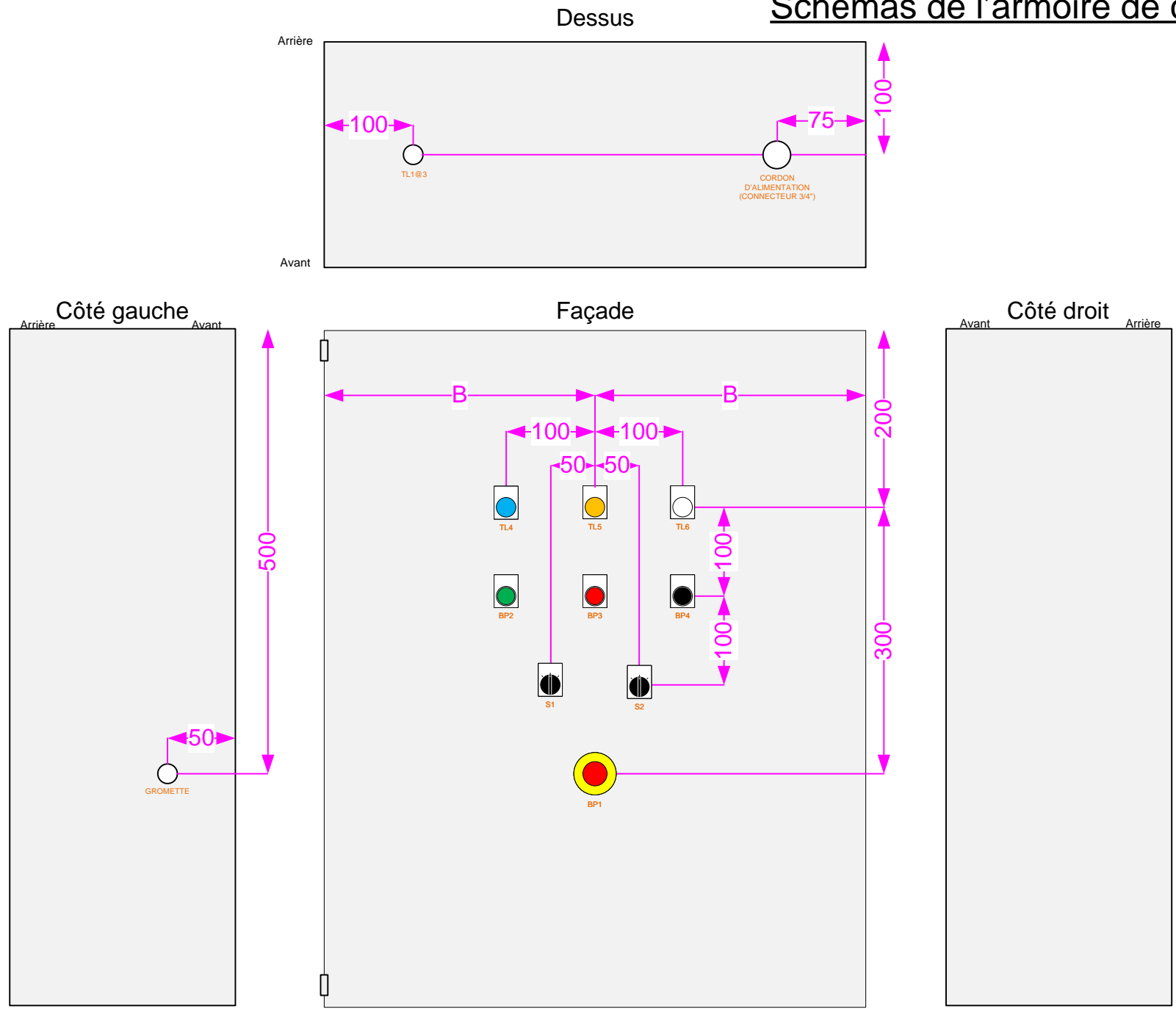

NOTE: LES MESURES DES TROUS SOUS L'ARMOIRE SONT DES SUGGESTIONS

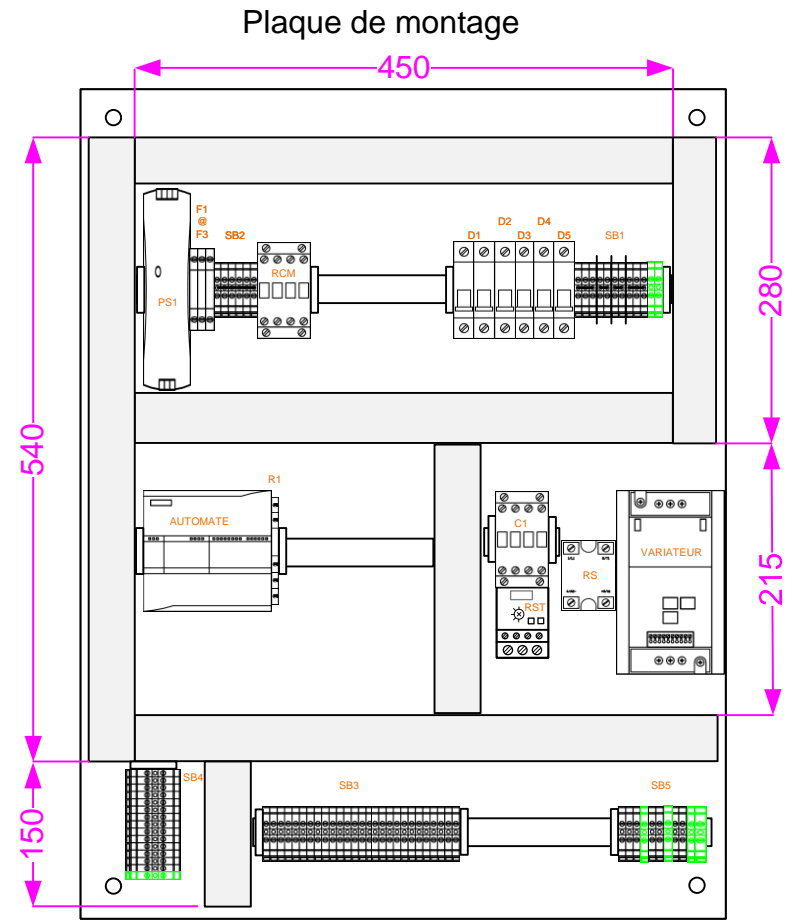
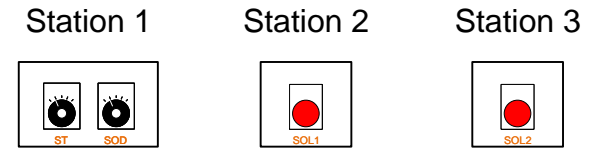

NOTE: LES MESURES DE LA PLAQUE DE MONTAGE SONT IMPOSÉES

| CODE | DESCRIPTION | DATE | DESSIN |
|------|-----------------|--------|--------|
| - | - | - | - |
| - | - | - | - |
| - | - | - | - |
| A | PRÉ-PUBLICATION | 12-Jan | É.B. |



OLYMPIADES QUÉBÉCOISES DES MÉTIERS ET TECHNOLOGIES
MÉTIER 19
ÉLECTRONIQUE INDUSTRIELLE

| | |
|----------------|---|
| 3 | 4 |
| CONCOURS: 2025 | |
| DATE: Jan-2025 | |

Schémas de disposition sur le mur

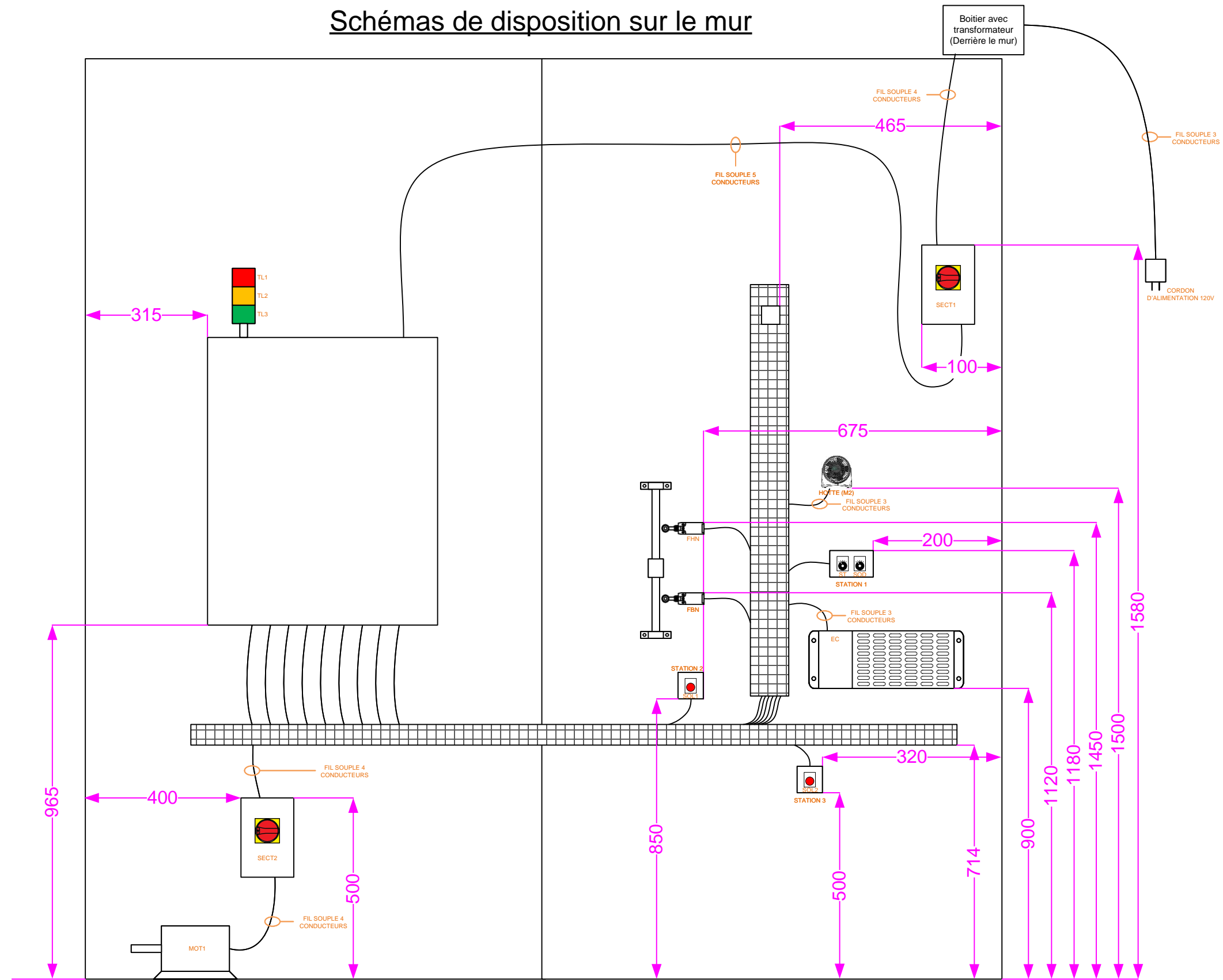

NOTE: LE POSITIONNEMENT DES COMPOSANTS SUR CE DESSIN N'EST PAS TOUT À FAIT À L'ÉCHELLE

| | | | |
|------|-----------------|--------|--------|
| - | - | - | - |
| - | - | - | - |
| - | - | - | - |
| A | PRÉ-PUBLICATION | 12-Jan | É.B. |
| CODE | DESCRIPTION | DATE | DESSIN |



OLYMPIADES QUÉBÉCOISES DES MÉTIERS ET TECHNOLOGIES
MÉTIER 19
ÉLECTRONIQUE INDUSTRIELLE

4 / 4
 CONCOURS: **2025**
 DATE: Jan-2025